

*TB 9-6625-2287-24

DEPARTMENT OF THE ARMY TECHNICAL BULLETIN

CALIBRATION PROCEDURE FOR ELECTRONIC VOLTMETERS AN/URM-145 (ME-247/U) AND AN/URM-145A (ME-247A/U)

Headquarters, Department of the Army, Washington, DC
26 November 2008

Distribution Statement A: Approved for public release; distribution is unlimited.

REPORTING OF ERRORS AND RECOMMENDING IMPROVEMENTS

You can improve this manual. If you find any mistakes or if you know of a way to improve these procedures, please let us know. Mail your letter or DA Form 2028 (Recommended Changes to Publications and Blank Forms) directly to: Commander, U.S. Army Aviation and Missile Command, ATTN: AMSAM-MMC-MA-NP, Redstone Arsenal, AL 35898-5000. A reply will be furnished to you. You may also send in your comments electronically to our E-mail address: 2028@redstone.army.mil or by fax 256-842-6546/DSN 788-6546. For the World Wide Web use: <https://amcom2028.redstone.army.mil>. Instructions for sending an electronic 2028 can be found at the back of this manual.

SECTION		Paragraph	Page
I.	IDENTIFICATION AND DESCRIPTION		
	Test instrument identification	1	2
	Forms, records, and reports.....	2	2
	Calibration description	3	2
II.	EQUIPMENT REQUIREMENTS		
	Equipment required.....	4	2
	Accessories required.....	5	2
III.	CALIBRATION PROCESS		
	Preliminary instructions	6	3
	Equipment setup	7	3
	Accuracy and linearity	8	4
	Frequency response.....	9	9
	Final procedure	10	10

*This bulletin supersedes TB 9-6625-2287-35 dated 15 October 2003.

SECTION I IDENTIFICATION AND DESCRIPTION

1. Test Instrument Identification. This bulletin provides instructions for the calibration of Electronic Voltmeters, AN/URM-145 (ME-247/U) and AN/URM-145A (ME-247A/U). The manufacturer's manual, TM 11-6625-524-15-1 and TM 11-6625-524-14 were used as the prime data sources in compiling these instructions. The equipment being calibrated will be referred to as the TI (test instrument) throughout this bulletin.

a. Model Variations. Variations among models are indicated in text.

b. Time and Technique. The time required for this calibration is approximately 4 hours, using the dc and low frequency technique.

2. Forms, Records, and Reports

a. Forms, records, and reports required for calibration personnel at all levels are prescribed by TB 750-25.

b. Adjustments to be reported are designated (R) at the end of the sentence in which they appear. When adjustments are in tables, the (R) follows the designated adjustment. Report only those adjustments made and designated with (R).

3. Calibration Description. TI parameter and performance specifications which pertain to this calibration are listed in table 1.

Table 1. Calibration Description

Test instruments parameters	Performance specifications ¹		
	Voltage ranges (V)	Range accuracy (FS)	Frequency response
AN/URM-145 (ME-247/U)	0.003 to 3	±10% ±5%	20 to 50 kHz 50 kHz to 400 MHz
AN/URM-145A (ME-247A/U)	0.003 to 3	±5%	10 kHz to 200 MHz

¹Verified to 100 MHz for all systems codes except COO; for COO, verify to 400 MHz.

SECTION II EQUIPMENT REQUIREMENTS

4. Equipment Required. Table 2 identifies the specific equipment to be used in this calibration procedure. This equipment is issued with Secondary Transfer Calibration Standards Set AN/GSM-287 or AN/GSM-705. Alternate items may be used by the calibrating activity. The items selected must be verified to perform satisfactorily prior to use and must bear evidence of current calibration. The equipment must meet or exceed the minimum use specifications listed in table 2. The accuracies listed in table 2 provide a four-to-one ratio between the standard and TI.

5. Accessories Required. The accessories required for this calibration are common usage accessories issued as indicated in paragraph 4 above and are not listed in this calibration procedure.

Table 2. Minimum Specifications of Equipment Required

Common name	Minimum use specifications	Manufacturer and model (part number)
CALIBRATOR	Frequency range: 10 kHz to 1 MHz Voltage range: 0.20 mV to 3.15 V ac Accuracy: ± 1.25	Fluke, Model 5720A (5700A/EP) (p/o MIS-35947); w amplifier, Fluke 5725A/AR (5725A/AR)
MEASURING RECEIVER	Frequency range: 10 to 400 MHz mV range: 90 to 110 mV ac Accuracy: ± 1.25	Measuring receiver system N5530S consisting of: Spectrum Analyzer, Agilent Model E4440A (E4440A), Power meter, Agilent Model E4419B (E4419B), and Sensor module, Agilent Model N5532A opt 504 (504)
POWER SPLITTER	Frequency range: 10 to 400 MHz Port-to-port tracking accuracy: ± 0.15 dB	Weinschel, Model 1870A (7916839)
SIGNAL GENERATOR	Range: 3 to 400 MHz Output amplitude variable from 90 to 110 mV	Aeroflex, Model 2023B (2023B) or (SG-1207/U)

SECTION III CALIBRATION PROCESS

6. Preliminary Instructions

a. The instructions outlined in paragraphs 6 and 7 are preparatory to the calibration process. Personnel should become familiar with the entire bulletin before beginning the calibration.

b. Items of equipment used in this procedure are referenced within the text by common name as listed in table 2.

c. Unless otherwise specified, verify the result of each test and, whenever the test requirement is not met, take corrective action before continuing with the calibration. Adjustments required to calibrate the TI are included in the procedure. Additional maintenance information is contained in the manufacturer's manual, TM 11-6625-524-15-1 and TM 11-6625-524-14 for this TI.

d. Unless otherwise specified all controls and control settings refer to the TI.

7. Equipment Setup

WARNING

HIGH VOLTAGE is used or exposed during the performance of this calibration. DEATH ON CONTACT may result if personnel fail to observe safety precautions. REDUCE OUTPUT(s) to minimum after each step within the performance check where applicable.

- a. Mechanically zero TI meter.
- b. Connect RF probe to PROBE jack.

NOTE

The RF probe authorized for use with TI must have serial numbers matching the TI serial numbers. If a new RF probe is calibrated with TI, annotate new RF probe with TI serial number. Do not use any RF probe not calibrated with TI.

- c. Connect TI to a 115 V ac source.
- d. Set **OFF-ON** switch to **ON**.
- e. Set **RANGE-FULL-SCALE** switch to **.001 VOLTS**.
- f. Replace RF probe tip with test adapter (50 Ω feedthrough termination.)
- g. Adjust **BALANCE** control for minimum meter detection.
- h. Replace test adapter (50 Ω feedthrough termination) with RF probe tip.
- i. Allow TI and measuring receiver to warm-up for 30 minutes.

NOTE

Ensure proper calibration factors are used for measuring receiver sensor module selected.

8. Accuracy and Linearity

a. Performance Check

- (1) Adjust calibrator for wideband operation.
- (2) Connect calibrator **WIDEBAND OUTPUT** (without 50 Ω pad) to TI RF probe using 50 Ω feedthrough termination supplied with TI.
- (3) Adjust calibrator frequency controls for 300 kHz output.
- (4) Adjust calibrator voltage output controls for a TI meter indication specified in table 3. If calibrator does not indicate within the limits specified in table 3, perform **b** below.
- (5) Repeat technique of (4) above for remaining **RANGE-FULL-SCALE VOLTS** setting listed in table 3.
- (6) Set calibrator to standby.
- (7) Disconnect RF probe from calibrator output.

Table 3. Range Accuracy and Linearity

RANGE-FULL-SCALE VOLTS scale setting	Test instrument meter indications (V)	Calibrator indications	
		Min	Max
0.001	0.0009	0.80 mV	1.0 mV
0.003	0.001	0.85 mV	1.15 mV
	0.002	1.85 mV	2.15 mV
	0.003	2.85 mV	3.15 mV

Table 3. Range Accuracy and Linearity - Continued

RANGE-FULL-SCALE VOLTS scale setting	Test instrument meter indications (V)	Calibrator indications	
		Min	Max
0.01	0.003	2.5 mV	11.5 mV
	0.006	5.5 mV	21.5 mV
	0.009	8.5 mV	31.5 mV
0.03	0.01	8.5 mV	11.5 mV
	0.02	18.5 mV	21.5 mV
	0.03	28.5 mV	31.5 mV
0.1	0.03	25.0 mV	35.0 mV
	0.06	55.0 mV	65.0 mV
	0.09	85.0 mV	95.0 mV
0.3	0.1	85.0 mV	115.0 mV
	0.2	185.0 mV	215.0 mV
	0.3	0.285 V	0.315 V
1	0.3	0.250 V	0.350 V
	0.6	0.550 V	0.650 V
	0.9	0.850 V	0.950 V
3	1	0.850 V	1.15 V
	2	1.85 V	2.15 V
	3	2.85 V	3.15 V

b. Adjustments. Perform (1) through (12) below for AN/URM-145 (ME-247/U). Perform (23) through (33) below for AN/URM-145A (ME-247A/U) with serial number 2661 and above.

NOTE

Adjustment numbers 1 through 6 are located from front to rear on right side of TI cabinet.

NOTE

Calibrator operating frequency is 300 kHz.

NOTE

Ensure RF probe is connected to calibrator **WIDEBAND OUTPUT** before proceeding to (1) below.

(1) Set **RANGE-FULL-SCALE** switch to **1-VOLTS**. Adjust calibrator for 0.3 V ac output at 300 kHz and then adjust adjustment number 1 for TI meter indication between 0.25 and 0.35 (ideal 0.3 V ac).

(2) Adjust calibrator for 0.9 V ac output at 300 kHz and then adjust adjustment number 2 for TI meter indication between 0.85 and 0.95 (ideal 0.9 V ac).

(3) Set **RANGE-FULL-SCALE** switch to **3-VOLTS**. Adjust calibrator for 2.5 V ac output and then adjust adjustment number 3 for a TI indication between 2.35 and 2.65 V ac (ideal 2.5 V ac) (R).

(4) Set **RANGE-FULL-SCALE** switch to **.3-VOLTS**. Adjust calibrator for 0.25 V ac output and then adjust adjustment number 4 for a TI indication between 0.235 and 0.265 V ac (ideal 0.25 V ac) (R).

(5) Set **RANGE-FULL-SCALE** switch to **.1-VOLTS**. Adjust calibrator for 0.09 V ac output and then adjust adjustment number 5 for a TI indication between 0.085 and 0.095 V ac (ideal 0.09 V ac) (R).

(6) Set **RANGE-FULL-SCALE** switch to **.01-VOLTS**. Adjust calibrator for 0.003 V ac output and then adjust adjustment number 6 for a TI indication between 0.0025 and 0.0035 V ac (ideal 0.003 V ac) (R).

NOTE

Adjustment numbers 7 through 11 are located from rear to front on left side of TI cabinet.

(7) Adjust calibrator for 0.005 V ac output and then adjust adjustment number 7 for a TI indication between 0.0045 and 0.0055 V ac (ideal 0.005 V ac) (R).

(8) Adjust calibrator for 0.009 V ac output and then adjust adjustment number 8 for a TI indication between 0.0085 and 0.0095 V ac (ideal 0.009 V ac) (R).

(9) Set **RANGE-FULL-SCALE** switch to **.03-VOLTS**. Adjust calibrator for 0.025 V ac output and then adjust adjustment number 9 for a TI indication between 0.0235 and 0.0265 V ac (ideal 0.025 V ac) (R).

(10) Set **RANGE-FULL-SCALE** switch to **.003-VOLTS**. Adjust calibrator for 0.0025 V ac output and then adjust adjustment number 10 for a TI indication between 0.00235 and 0.00265 V ac (ideal 0.0025 V ac) (R).

(11) Set **RANGE-FULL-SCALE** switch to **.001-VOLTS**. Adjust calibrator for 0.0009 V ac output and then adjust adjustment number 11 for a TI indication between 0.0008 and 0.001 V ac (ideal 0.0009 V ac) (R).

(12) Disconnect RF probe from calibrator.

NOTE

Calibrator operating frequency is 300 kHz.

NOTE

Adjustment numbers 1 through 6 are located from front to rear on right side of TI cabinet.

NOTE

Ensure RF probe is connected to calibrator **WIDEBAND OUTPUT** before proceeding to (13) below.

(13) Set **RANGE-FULL-SCALE** switch to **1-VOLTS**. Adjust calibrator for 0.9 V ac output at 300 kHz and then adjust adjustment number 1 for TI meter indication between 0.85 and 0.95 (ideal 0.9 V ac).

(14) Set **RANGE-FULL-SCALE** switch to **3-VOLTS**. Adjust calibrator for 2.5 V ac output and then adjust adjustment number 2 for a TI indication between 2.35 and 2.65 V ac (ideal 2.5 V ac) (R).

(15) Set **RANGE-FULL-SCALE** switch to **.3-VOLTS**. Adjust calibrator for 0.028 V ac output and then adjust adjustment number 3 for a TI indication between 0.265 and 0.295 V ac (ideal 0.28 V ac) (R).

(16) Set **RANGE-FULL-SCALE** switch to **A-VOLTS**. Adjust calibrator for 0.03 V ac output and then adjust adjustment number 4 for a TI indication between 0.025 and 0.035 V ac (ideal 0.03 V ac) (R).

(17) Adjust calibrator for 0.09 V ac output and then adjust adjustment number 5 for a TI indication between 0.085 and 0.095 V ac (ideal 0.09 V ac) (R).

(18) Set **RANGE-FULL-SCALE** switch to **.03-VOLTS**. Adjust calibrator for 0.028 V ac output and then adjust adjustment number 6 for a TI indication between 0.0265 and 0.0295 V ac (ideal 0.028 V ac) (R).

NOTE

Adjustment numbers 7 through 9 are located from rear to front on left side of TI cabinet.

(19) Set **RANGE-FULL-SCALE** switch to **.01-VOLTS**. Adjust calibrator for 0.009 V ac output and then adjust adjustment number 7 for a TI indication between 0.0085 and 0.0095 V ac (ideal 0.009 V ac) (R).

(20) Set **RANGE-FULL-SCALE** switch to **.003-VOLTS**. Adjust calibrator for 0.0028 V ac output and then adjust adjustment number 8 for a TI indication between 0.00265 and 0.00295 V ac (ideal 0.0028 V ac) (R).

(21) Set **RANGE-FULL-SCALE** switch to **.001-VOLTS**. Adjust calibrator for 0.0009 V ac output and then adjust adjustment number 9 for a TI indication between 0.0008 and 0.001 V ac (ideal 0.0009 V ac) (R).

(22) Disconnect RF probe from calibrator.

NOTE

Perform (23) through (33) below for AN/URM-145A (ME-247A/U).

NOTE

Adjustment numbers 1 through 6 are located from front to rear on right side of TI cabinet.

NOTE

Calibrator operating frequency is 300 kHz.

NOTE

Ensure RF probe is connected to calibrator **WIDEBAND OUTPUT** before proceeding to (23) below.

(23) Set **RANGE-FULL-SCALE** switch to **1-VOLTS**. Adjust calibrator for 0.3 V ac output at 300 kHz and then adjust adjustment number 1 for TI meter indication between 0.25 and 0.35 (ideal 0.3 V ac).

(24) Set **RANGE-FULL-SCALE** switch to **3-VOLTS**. Adjust calibrator for 2.5 V ac output and then adjust adjustment number 2 for a TI indication between 2.35 and 2.65 V ac (ideal 2.5 V ac) (R).

(25) Set **RANGE-FULL-SCALE** switch to **1-VOLTS**. Adjust calibrator for 0.9 V ac output at 300 kHz and then adjust adjustment number 3 for TI meter indication between 0.85 and 0.95 (ideal 0.9 V ac).

(26) Set **RANGE-FULL-SCALE** switch to **.3-VOLTS**. Adjust calibrator for 0.28 V ac output and then adjust adjustment number 4 for a TI indication between 0.265 and 0.295 V ac (ideal 0.28 V ac) (R).

(27) Set **RANGE-FULL-SCALE** switch to **.1-VOLTS**. Adjust calibrator for 0.03 V ac output and then adjust adjustment number 5 for a TI indication between 0.025 and 0.035 V ac (ideal 0.03 V ac) (R).

(28) Adjust calibrator for 0.09 V ac output and then adjust adjustment number 6 for a TI indication between 0.085 and 0.095 V ac (ideal 0.09 V ac) (R).

NOTE

Adjustment numbers 7 through 9 are located from rear to front on left side of TI cabinet.

(29) Set **RANGE-FULL-SCALE** switch to **.03-VOLTS**. Adjust calibrator for 0.028 V ac output and then adjust adjustment number 7 for a TI indication between 0.0265 and 0.0295 V ac (ideal 0.028 V ac) (R).

(30) Set **RANGE-FULL-SCALE** switch to **.01-VOLTS**. Adjust calibrator for 0.009 V ac output and then adjust adjustment number 8 for a TI indication between 0.0085 and 0.0095 V ac (ideal 0.009 V ac) (R).

(31) Set **RANGE-FULL-SCALE** switch to **.003-VOLTS**. Adjust calibrator for 0.0028 V ac output and then adjust adjustment number 9 for a TI indication between 0.00265 and 0.00295 V ac (ideal 0.0028 V ac) (R).

(32) Set **RANGE-FULL-SCALE** switch to **.001-VOLTS**. Adjust calibrator for 0.0009 V ac output and then adjust adjustment number 10 for a TI indication between 0.0008 and 0.001 V ac (ideal .0009 V ac) (R).

(33) Disconnect RF probe from calibrator.

9. Frequency Response

a. Performance Check

- (1) Connect calibrator **WIDEBAND OUTPUT** (without 50 Ω pad) to TI RF probe using 50 Ω feedthrough termination supplied with TI.
- (2) Set **RANGE-FULL-SCALE** switch to **.1-VOLTS**.
- (3) Adjust calibrator frequency controls to value listed in calibrator frequency limits specified in table 4.
- (4) Adjust calibrator output voltage controls for .1 V indication on TI meter. Calibrator voltage output will be within the limits specified in table 4.
- (5) Repeat technique of (3) and (4) above for remaining calibrator frequency settings listed in table 4.

Table 4. Frequency Response

Calibrator frequency settings (kHz)	Calibrator output voltage indications ¹ (mV)		Calibrator output voltage indications ² (mV)	
	Min	Max	Min	Max
10	- - -	- - -	95	105
20	90	110	95	105
50	90	110	95	105
100	95	105	95	105
150	95	105	95	105
500	95	105	95	105
1000	95	105	95	105

¹AN/URM-145 (ME-247/U).

²AN/URM-145A(ME-247A/U).

- (6) Connect equipment as shown in figure 1.

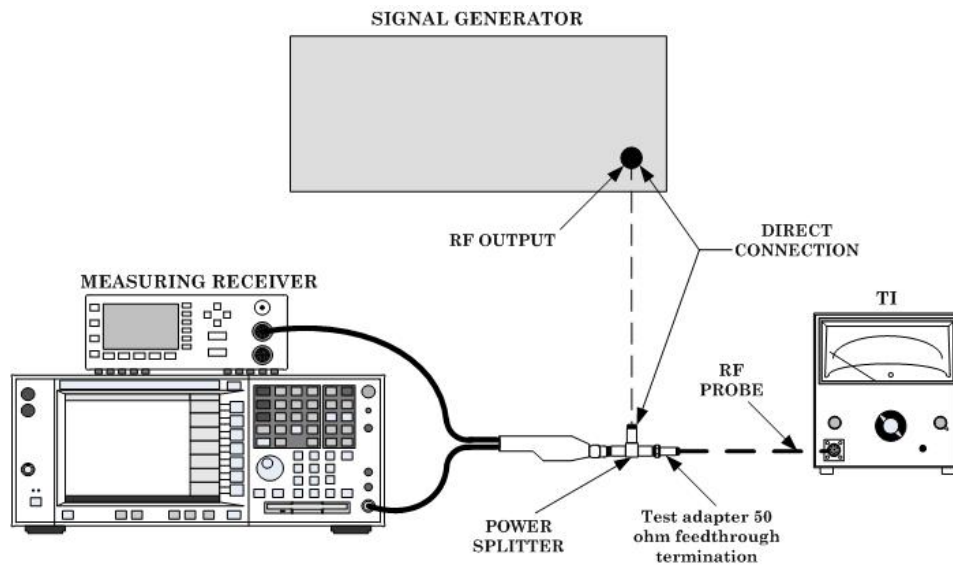

Figure 1. Frequency response - equipment setup.

(7) Adjust signal generator frequency controls to value listed in signal generator frequency settings listed in table 5.

(8) Configure measuring receiver to measure RF power in mV.

(9) Adjust signal generator output voltage controls for .1 V indication on TI meter. Measuring receiver indication will be within limits specified in table 5.

(10) Adjust signal generator for remaining frequency settings listed in table 5. Measuring receiver indication for remaining frequency settings will be within limits specified in table 5.

Table 5. Frequency Response¹

Signal generator frequency settings (MHz)	Measuring receiver indications ² (mV)		Measuring receiver indications ³ (mV)	
	Min	Max	Min	Max
3	95	105	95	105
5	95	105	95	105
7	95	105	95	105
10	95	105	95	105
20	95	105	95	105
50	95	105	95	105
100	95	105	95	105
175	95	105	95	105
200	95	105	90	110
300	95	105	90	110
400	95	105	90	110

¹Verified to 100 MHz for all systems codes except COO; for COO, verify to 400 MHz.

²AN/URM-145 (ME-247/U).

³AN/URM-145A (ME-247A/U).

10. Final Procedure

- a. Deenergize and disconnect all equipment.
- b. Annotate and affix DA label/form in accordance with TB 750-25.

By Order of the Secretary of the Army:

Official

JOYCE E. MORROW
*Administrative Assistant to the
Secretary of the Army*
0719028

GEORGE W. CASEY, JR.
*General, United States Army
Chief of Staff*

Distribution:

To be distributed in accordance with the initial distribution number (IDN) 344467, requirements for calibration procedure TB 9-6625-2287-24.

INSTRUCTIONS FOR SUBMITTING AN ELECTRONIC 2028

The following format must be used if submitting an electronic 2028. The subject line must be exactly the same and all fields must be included; however, only the following fields are mandatory: 1, 3, 4, 5, 6, 7, 8, 9, 10, 13, 15, 16, 17, and 27.

From: "Whomever" whomever@redstone.army.mil

To: <2028@redstone.army.mil

Subject: DA Form 2028

1. **From:** Joe Smith
2. **Unit:** home
3. **Address:** 4300 Park
4. **City:** Hometown
5. **St:** MO
6. **Zip:** 77777
7. **Date Sent:** 19-OCT-93
8. **Pub no:** 55-2840-229-23
9. **Pub Title:** TM
10. **Publication Date:** 04-JUL-85
11. **Change Number:** 7
12. **Submitter Rank:** MSG
13. **Submitter FName:** Joe
14. **Submitter MName:** T
15. **Submitter LName:** Smith
16. **Submitter Phone:** 123-123-1234
17. **Problem:** 1
18. **Page:** 2
19. **Paragraph:** 3
20. **Line:** 4
21. **NSN:** 5
22. **Reference:** 6
23. **Figure:** 7
24. **Table:** 8
25. **Item:** 9
26. **Total:** 123
27. **Text**

This is the text for the problem below line 27.

